

**INSTRUCTION  
MANUAL  
FT-7**

**YAESU MUSEN CO., LTD.**

HF MOBILE TRANSCEIVER  
FT-7

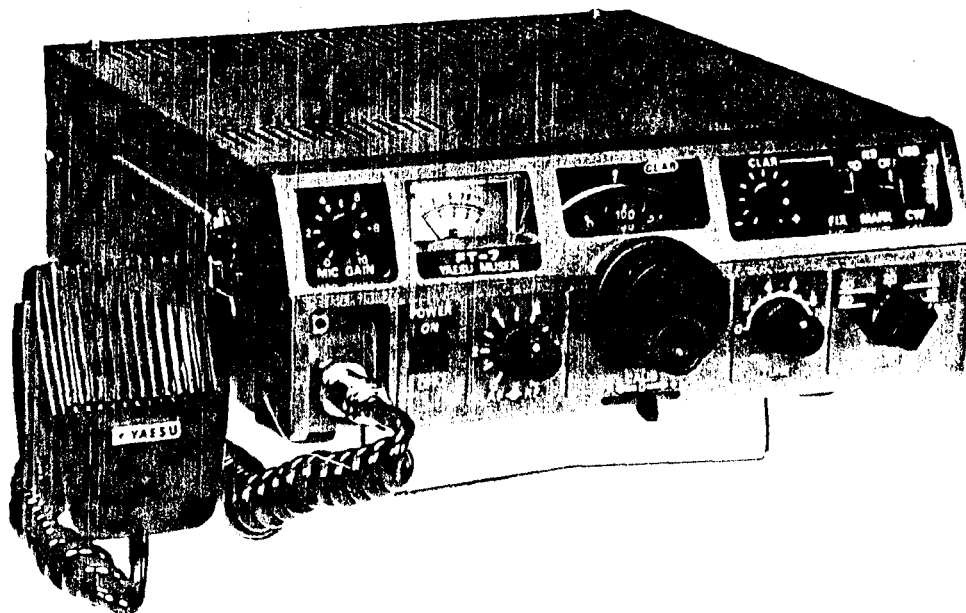

The all-solid-state FT-7 mobile transceiver provides high performance on the 80 through 10 meter bands. The operator may select upper or lower sideband (USB, LSB) or CW operation, and the compact package contains many features engineered for maximum convenience during mobile operation.

The TUNE control provides single-knob peaking of all transceiver circuits, thus eliminating inconvenient plate and load controls. Transmitter final amplifier input power is 20 watts DC. A high performance noise blanker minimizes impulse-type noise such as that commonly found in mobile applications. Also built-in are a 100 kHz crystal calibrator and receiver offset tuning (clarifier). For CW operation, semi-break-in with sidetone is provided.

The receiver front end utilizes MOS FET and Schottky diode circuitry for maximum sensitivity and immunity from overload.

The operator may select between either the internal VFO or a fixed (crystal controlled) channel. An external VFO may be used with the FT-7 to provide either VFO or crystal control of the transmit and/or receive frequency.

The FT-7 operates directly from a 13.5 VDC power source. For base station operation, the FP-7 or FP-4 power supply may be used to provide the necessary voltage.

In order to derive the maximum satisfaction from your new FT-7, we recommend that you read this instruction manual thoroughly so as to understand fully the functions of the controls and switches.

## SPECIFICATIONS

Frequency coverage: 80m 3.5-4.0 MHz  
40m 7.0-7.5 MHz  
20m 14.0-14.5 MHz  
15m 21.0-21.5 MHz  
10m \*28.5-29.0 MHz

\*28.5-29.0 MHz crystal installed, other crystals available as an option

Power requirements: 13.5 VDC  $\pm$  10%

Power consumption: 13.5 VDC -3A transmit, 0.4 A receive

Dimensions: 230 (W) x 80 (H) x 290 (D) mm

Weight: 5 kg.

### TRANSMITTER

Emission: LSB, USB (A3J) CW (A1)

Input power: A1, A3j, 20 watts DC

Carrier suppression: Better than 50 dB below rated output

Unwanted sideband suppression: Better than 50 dB @ 1000 Hz

Spurious emission: Better than -40 dB

Distortion products: Better than -31 dB

Transmitter frequency response: 350-2700 Hz -6 dB

Frequency stability: Less than 300 Hz drift from a cold start;  
less than 100 Hz over a 30 minute period  
after warm-up.

Antenna output impedance: 50 ohms nominal

Microphone input impedance: 500 Ohms nominal

### RECEIVER

Sensitivity: 0.25 uV for S/N 10 dB

Image rejection: Better than 50 dB

IF rejection: Better than 50 dB

Selectivity: -6 dB: 2.4 KHz  
-60 dB: 4.0 KHz

Audio output: 3 watts @ 10% THD

Audio output impedance: 4 Ohms

## MOBILE INSTALLATION

For mobile service, the FT-7 should be installed where the controls, indicators, and microphone are easily visible and accessible for operation. The unit may be mounted in any position without loss of performance. Suitable locations are under the dash, atop transmission tunnel, etc. A universal mounting bracket is supplied with the transceiver for this purpose. Install the FT-7 as follows:

1. Use the universal mounting bracket as a template to locate the mounting holes. Use a  $3/16$ " diameter drill for these holes and allow clearance for the transceiver, its controls, and all connecting cables. Secure the mounting bracket with the screws, washers, and nuts that are supplied, as shown in figure 1.
2. Install the transceiver on the mounting bracket using four screws, two on each side. The angle of the transceiver with respect to the bracket may be varied by changing mounting holes.
3. The microphone hanger may be affixed to any convenient place for access to the microphone.

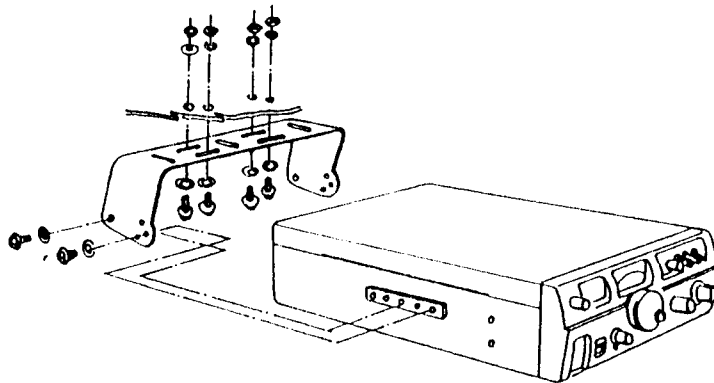

4. The supplied power cable may be plugged directly into the vehicle's cigarette lighter receptacle for casual operation if desired. For permanent installation, the lighter plug may be removed and the leads routed directly to the battery (red positive, black negative/ground), or the nearest termination to the battery, e.g. ignition switch, fuse block, etc. If it is necessary to extend the power leads over a considerable distance, use #16AWG insulated copper wire and do not extend the leads further than necessary to avoid excessive voltage drop.

#### CAUTION

BEFORE CONNECTING THE POWER CABLE TO THE TRANSCIVER, CHECK THE BATTERY VOLTAGE WITH THE ENGINE RUNNING (BATTERY CHARGING). IF THE VOLTAGE EXCEEDS 15 VOLTS DC, THE REGULATOR SHOULD BE READJUSTED SO THE HIGHEST CHARGING RATE DOES NOT EXCEED 15 VOLTS. ALSO, BE SURE TO OBSERVE PROPER POLARITY WHEN MAKING BATTERY CONNECTIONS (REVERSED POLARITY WILL NOT DAMAGE THE FT-7 DUE TO THE PROTECTIVE CIRCUITRY INCORPORATED IN THE DESIGN. HOWEVER, THE EQUIPMENT WILL NOT OPERATE UNDER THIS CONDITION).

5. Connect the power cable to the POWER receptacle on the rear panel.
6. Connect a 50 Ohm antenna feedline to the ANT receptacle on the rear panel.
7. Connect the microphone cable to the 4-pin microphone receptacle on the front panel.
8. Connect a key, if desired, to the KEY jack on the rear panel.
9. An external 4 Ohm speaker may be connected to the SP receptacle on the rear panel if desired (this automatically disconnects the internal speaker). Use the external speaker plug provided.

#### BASE STATION INSTALLATION

As a base station, the FT-7 requires a source of 13.8 VDC at 3.0 amperes. The FP-7, FP-4, FP-301, and FP-301D AC power supplies will provide the necessary power.

## FRONT PANEL CONTROLS

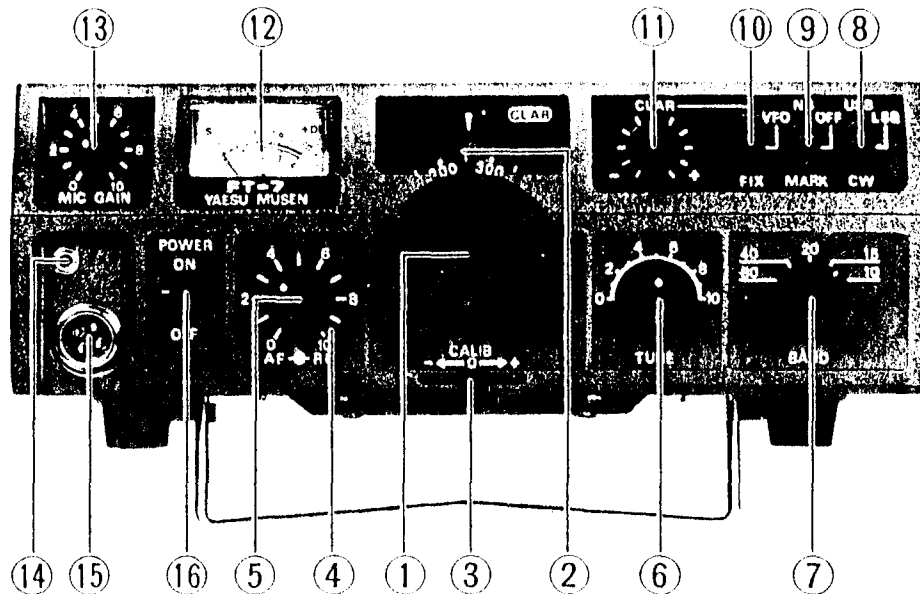

- (1) TUNING KNOB  
This knob controls the main VFO frequency. One revolution of the knob covers 16 KHz of bandwidth.
- (2) DIAL  
The main tuning dial has numerical calibrations every 10 KHz, and marks every 1 KHz. The sub-dial is numerically calibrated every 100 KHz, with an additional mark every 50 KHz.
- (3) CALIB  
When the MARK switch is activated, the 100 KHz calibrator becomes operational, and the CALIB control allows zeroing the calibrator signal with the tuning dial calibration mark.
- (4) RF GAIN  
The RF GAIN control varies the gain of the receiver RF and IF amplifiers. Clockwise rotation increases the gain level.
- (5) AF GAIN  
The AF GAIN control varies the audio output level at the speaker and earphone jack. Clockwise rotation increases the gain level.
- (6) TUNE  
This control tunes all the transceiver signal circuits for the frequency being used.
- (7) BAND  
The BAND switch selects the frequency band desired. Coverage of 80 through 10 meters is provided.
- (8) MODE  
The MODE switch chooses the desired mode: USB, LSB, or CW.

- (9) NB/MARK  
 When this switch is placed in the NB position, the noise blanker circuitry is activated.  
 When placed in the MARK position, the 100 KHz calibrator is activated for calibrating the main tuning dial.
- (10) CLAR/VFO/FIX  
 This switch determines the source of frequency control. In the VFO position, frequency control is by means of the FT-7 main dial VFO. In the CLAR position, frequency control is still by means of the main VFO, but the clarifier control will allow receiver offset tuning of  $\pm 2$ KHz. In the FIX position, crystal control of the transceive frequency is possible.
- When the CLAR or FIX positions are used, a small light will so indicate in the window above the main tuning dial.
- (11) CLARIFIER  
 This control allows  $\pm 2$ KHz receiver offset tuning without affecting the transmitter frequency, when the switch (10) is placed in the uppermost position.
- (12) METER  
 The front panel meter functions as an S meter while on receive. In the transmit condition, the meter reads collector current for the final amplifier transistors on a scale of 0-4 Amps.
- (13) MIC GAIN  
 This control varies the gain of the microphone amplifier stage. Clockwise rotation increases the microphone amplifier gain.
- (14) EAR  
 This jack accommodates a 4-8 Ohm headphone through a miniature phone plug. When the plug is inserted into this jack the external speaker jack and the internal speaker are disconnected.
- (15) MIC  
 A four-pin socket accommodates the microphone plug for microphone and PTT input.
- (16) POWER  
 This is the main power ON/OFF switch.

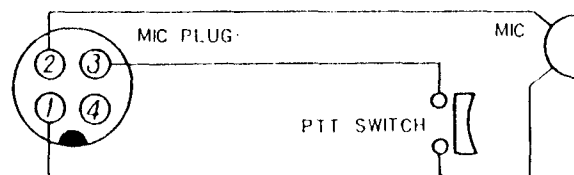

Microphone plug connection

## INSTALLATION

### ANTENNA CONSIDERATIONS

For full transmitter output power, the antenna system must present a resistive impedance of very close to 50 Ohms. The protective circuitry for the final transistors will automatically reduce the collector current and, hence, the power output, if a high SWR condition exists. If the SWR cannot be kept below 1.5:1 with respect to 50 Ohms an antenna coupler such as the Yaesu FC-301 should be used to secure a 50-Ohm load impedance for the FT-7.

When the SWR is 1.0:1, 100% output power is produced. With a 1.5:1 SWR, 80% output power is produced. At 2.0:1 the power is reduced to 50%, and at 3.0:1 it is 20% of the full rated output.

The YAESU RS- series of mobile antennas is designed for use with the FT-7. The RSM-2 and the RSE-2 element form the foundation for the system, and the RSL-3.5-28 whip resonators are utilized to provide HF band coverage. For two meter band coverage, the RSL-whip may be removed and the RSE-2 used as a two-meter antenna.

### IMPORTANT NOTE

BEFORE ATTEMPTING OPERATION OF YOUR FT-7, PLEASE READ THE FOLLOWING SECTIONS DEALING WITH POWER CONNECTIONS AND TUNE-UP CAREFULLY. WHILE THE FT-7 IS EXTREMELY STRAIGHT-FORWARD AS TO ITS OPERATION, THE OPERATOR MAY BE UN-FAMILIAR WITH THE FUNCTIONS OF SOME OF THE CONTROLS, AND THE FOLLOWING SECTIONS SHOULD MAKE THEM CLEAR.

### POWER SOURCES

The FT-7 is designed to operate from a 13.5 VDC power source capable of supplying 6 Amps continuous current. For mobile use, connect the power cord red lead to the positive battery terminal, and the black lead to the negative (ground) side.

For operation from 117 VAC, use the FP-7 or FP-4 power supply. If it is desired to use the FL-110 100-watt amplifier, the FP-301D or FP-301 power supply may be used to supply power for both the FT-7 and the FL-110.

RSL3.5 - [REDACTED]

RSL7A - [REDACTED]

RSL14 - [REDACTED]

RSL21 - [REDACTED]

RSL28 - [REDACTED]



★ RSM-2

■ ■ ★ RSE-2

## REAR APRON CONNECTIONS

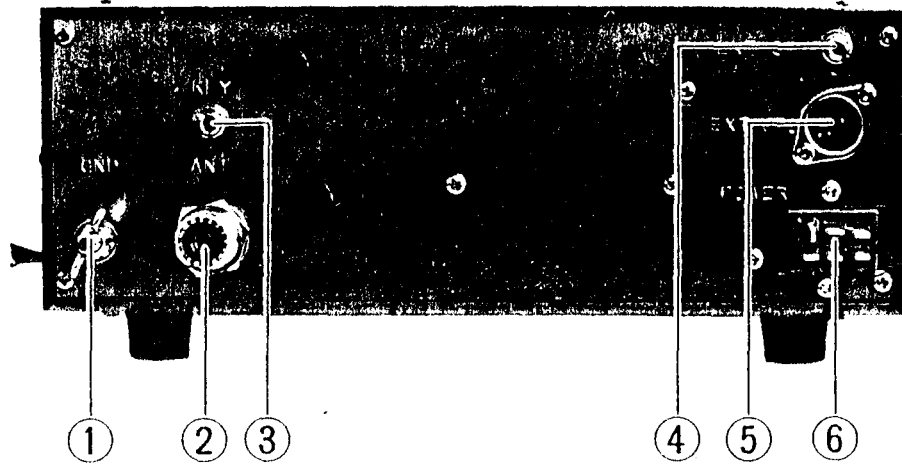

- (1) GND  
Ground connection to car body or earth ground.
- (2) ANT  
This is a standard M ("UHF") female coaxial connector for the antenna feedline.
- (3) KEY  
For CW operation, the key plug (miniature phone type) is inserted into this jack.
- (4) EXT SP  
An external 4 Ohm speaker may be connected to this jack.
- (5) EXT VFO  
This socket provides connections for an external VFO.
- (6) POWER  
The main power cord is connected at this point.

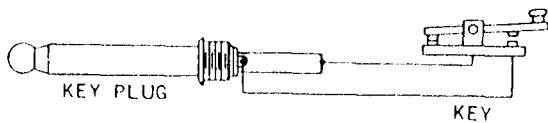

Key plug connection



Headphone and external speaker connection

## OPERATING INSTRUCTIONS

With the POWER switch in the OFF position, connect the power cord to the 6-pin POWER receptacle on the rear panel of the FT-7.

- (1) For SSB operation, LSB is used on the 3.5 and 7 MHz bands, while USB is standard on 14, 21, and 28 MHz. Preset the controls as follows:

MODE: Desired mode

NB/MARK: OFF

VFO/FIX/CLAR: VFO

DIAL: Desired frequency

TUNE: 12 o'clock position

BAND: Desired Band

AF GAIN: Fully counter-clockwise

RF GAIN: Fully clockwise

- (2) Flip the FT-7 POWER switch to ON. If using AC power, flip the FP-7 or FP-4 power switch to ON. The FT-7 dial light should be illuminated with the power on.
- (3) Adjust the AF GAIN control for a comfortable listening level.
- (4) Vary the TUNE control for maximum receiver background noise.
- (5) Rotate the DIAL as needed to tune in the desired frequency.
- (6) If a large excursion is made with the DIAL, the TUNE control may require readjustment. Also, the AF GAIN control will require adjustment to maintain a comfortable listening level.
- (7) The VFO/FIX/CLAR switch may be placed in the CLAR position to vary the receive frequency  $\pm$  2 kHz without changing the transmit frequency.
- (8) The NB/MARK control may be placed in the NB position to minimize interference due to noise.

### TUNE-UP

- (1) The initial tune-up procedure for CW and SSB is the same for both modes. Preset the controls as follows:

MODE: CW

DIAL: Desired frequency

TUNE: Peaked as per preceding section

BAND: Desired band

With the MODE switch in the CW position and no plug inserted in the KEY jack, the transmitter may be placed in the "key down" position for tuning by simply closing the microphone PTT button.

## ADVANCE PREPARATION

Before power is applied, the operator should read this manual carefully, and should inspect the transceiver to become familiar with the locations of all the switches and controls.

- (1) When initial tune-up is attempted, it is very desirable that a dummy load of 50 Ohm impedance be used, so as to prevent any confusion created by reduced power output because of high SWR. When an antenna is connected to the rear panel receptacle, it should be pre-tuned in advance with a different transmitter, so as not to damage the FT-7 output transistors with extremely high SWR.
- (2) A standard low impedance (500-600 Ohm) microphone should be connected to the microphone receptacle on the front panel.
- (3) For CW operation, a key should be connected to the jack on the rear panel.

## MAIN TUNING DIAL FREQUENCY READOUT

- (1) Coarse frequency determination is made by referring to the lower of the two analog dials. The lower one has numerical calibrations every 100 kHz and a calibration mark every 50 kHz. The upper dial has numerical calibrations every 10 kHz, with resolution marks to 1 kHz.
- (2) Frequency readout on all bands is determined by adding the frequency on the main tuning dial to the frequency of the lower band edge. For 40m, 20m, 15m, and 10m band segments A and C, the band edge begins at 000 (for example 7000 kHz on 40 m). On 80m and 10m band segments B and D, the lower band edge begins with 500 (for example, 28500 kHz on 10m B). Thus, a reading of 074 on the main tuning dial will represent 3574 kHz, 7074 kHz, 21074 kHz, 28074 kHz, 28574 kHz, 29074 kHz, or 29574 kHz, depending on the position of the band switch.

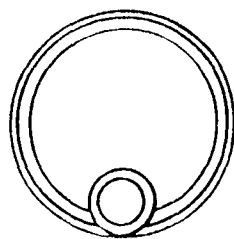
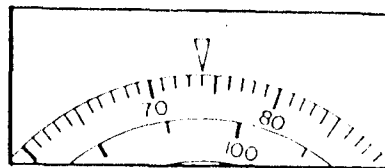

## ADVANCE PREPARATION

Before power is applied, the operator should read this manual carefully, and should inspect the transceiver to become familiar with the locations of all the switches and controls.

- (1) When initial tune-up is attempted, it is very desirable that a dummy load of 50 Ohm impedance be used, so as to prevent any confusion created by reduced power output because of high SWR. When an antenna is connected to the rear panel receptacle, it should be pre-tuned in advance with a different transmitter, so as not to damage the FT-7 output transistors with extremely high SWR.
- (2) A standard low impedance (500-600 Ohm) microphone should be connected to the microphone receptacle on the front panel.
- (3) For CW operation, a key should be connected to the jack on the rear panel.

## MAIN TUNING DIAL FREQUENCY READOUT

- (1) Coarse frequency determination is made by referring to the lower of the two analog dials. The lower one has numerical calibrations every 100 kHz and a calibration mark every 50 kHz. The upper dial has numerical calibrations every 10 kHz, with resolution marks to 1 kHz.
- (2) Frequency readout on all bands is determined by adding the frequency on the main tuning dial to the frequency of the lower band edge. For 40m, 20m, 15m, and 10m band segments A and C, the band edge begins at 000 (for example 7000 kHz on 40 m). On 80m and 10m band segments B and D, the lower band edge begins with 500 (for example, 28500 kHz on 10m B). Thus, a reading of 074 on the main tuning dial will represent 3574 kHz, 7074 kHz, 21074 kHz, 28074 kHz, 28574 kHz, 29074 kHz, or 29574 kHz, depending on the position of the band switch.

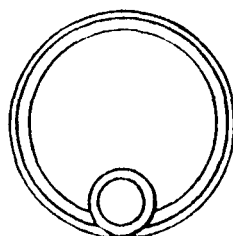
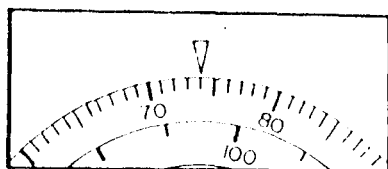

- (2) Turn the POWER switch to ON. If on AC power, turn FP-4 /FP-7 power switch to ON.
- (3) Press the microphone PTT switch to activate the transmitter.
- (4) Rotate the TUNE control for maximum meter reading.
- (5) Release the microphone PTT button to return to the receive condition.

### SSB OPERATION

- (1) Following the initial tune-up described above, place the MODE switch in the USB or LSB position as appropriate for the band in use.
- (2) Press the microphone PTT button and speak into the microphone in a normal voice. Advance the MIC GAIN control until the meter indicates 1/2 to 2/3 the level observed while tuning in the CW position.
- (3) Release the microphone PTT switch. You are now tuned up for SSB operation.
- (4) The MIC GAIN control should never be advanced more than necessary to achieve the 1/2 to 2/3 scale deflection, excessive mic gain may cause distortion of the output signal.

### CW OPERATION

- 1) Plug a key into the KEY jack on the rear panel. CAUTION: when using an electronic keyer, the operator should be sure that the keyer output transistor or relay is rated for the current and voltage present at the key jack. The key line is +8V at 300 uA key down current.
- 2) Set the MODE switch to CW
- 3) Automatic CW semi-break-in is utilized in the FT-7. When the key is closed, the transmitter is automatically activated, and when the key is opened, the transceiver returns to the receive condition after a slight delay. The length of the time delay can be varied to suit the operator by adjustment of VR702.
- 4) In the key down condition, the IC meter should indicate "3", while it should read "0" while in the transmit condition but "key up".

- 5) To ensure accurate keying, a sidetone monitor is built in. When the transmitter is keyed, this sidetone will be heard on the speaker. The sidetone volume level may be adjusted by varying VR701.
- 6) When the keying speed is very slow, the keying relay in the transceiver may return to receive in the middle of a letter or word. If this is the case, it may be to the advantage of the operator to use the PTT switch to activate the transmitter.

#### DIAL CALIBRATION

- 1) Set the NB/MARK switch to MARK and VFO/FIX switch to VFO position.
- 2) Set the main tuning dial to the 100 kHz position nearest the desired operating frequency.
- 3) Adjust the lever underneath the main tuning knob for zero beat against the marker signal.

## FIX (CRYSTAL CONTROLLED) OPERATION

Fixed channel operation is possible by using crystals installed in the FIX UNIT. The VFO/FIX switch must be placed in the FIX position. There is only one crystal controlled channel available per band with the FT-7.

Crystals used in the FT-7 must meet the specifications shown in Fig. 2, and they are available through your Yaesu dealer. Crystal frequencies must fall between 5500-5000 kHz. Frequency calculation is made from the formula  $F_x = F_1 - F_0$ , where  $F_x$  is the crystal frequency,  $F_0$  is the desired operating frequency, and  $F_1$  is a constant derived from Fig. 1.

For example, let us say that it is desired to operate on 7199 kHz LSB. Referring to Fig. 1, we see that for 40-meter LSB,  $F_1$  is 12501.5. Subtract  $F_0$  (7199 kHz) from  $F_1$  (12501.5) to equal 5302.5 kHz ( $F_x$ ). For example, let us say it is desired to operate on 21420 kHz USB. From Fig. 1,  $F_1$  is 26498.5; subtract 21420 from 26498.5 to equal  $F_x$  of 5078.5 kHz.

Inspection of the values of  $F_1$  in Fig. 1 will reveal that the 7199 kHz crystal for LSB will work on 14199 kHz, 21199 kHz, etc. Of course, LSB is not normally used on these bands. If the operator switches to USB, the operating frequency (in this case 7199, 14199, etc.) will be moved 3 kHz down to 7196, 14196, etc. If the move is made from LSB to CW, the frequency moves down 800 Hz (to 7198.2, 14198.2, etc.) except on 80 meters, where the shift is 1.2 kHz down.

MODE BAND	U S B	L S B	C W
80m	8998.5	9001.5	8999.3
40m	12498.5	12501.5	12500.7
20m	19498.5	19501.5	19500.7
15m	26498.5	26501.5	26500.7
10mA	33498.5	33501.5	33500.7
10mB	33998.5	34001.5	34000.7
10mC	34498.5	34501.5	34500.7
10mD	34998.5	35001.5	35000.7

Figure 1 (kHz)

Type	HC-25/U
Load Capacitance	30pF
Series Resistance	25 Ohms or less
Static Capacitance	7pF or less
Drive Level	5mW

Figure 2

## CIRCUIT DESCRIPTION

The FT-7 transceiver utilizes plug-in modules for the most efficient use of space and to simplify the trouble-shooting and repair process. The transceiver is all solid-state, and the receiver and transmitter operate in a single-conversion configuration utilizing a premix heterodyne technique which greatly reduces signal distortion in both the transmit and receive modes.

### RECEIVER

The incoming signal from the antenna is fed through the antenna relay RL2102, (normally open) band switch S1901, and the tuning circuit consisting of T1921-T1925 and VC1901 to pin 9 of the RF/MARK unit PB-1633. The signal is then fed to gate 1 of the RF amplifier Q104 (3SK40M), a dual-gate MOS FET. The AGC (Automatic Gain Control) voltage is applied to gate 2 of Q104 to control the gain of this stage, to avoid overloading in the following stages.

The amplified signal is fed through the passband tuning circuit to the mixer unit PB-1631. The buffer amplifier Q201 (2SC535A) is used to accomplish impedance matching between the RF amplifier and the diode mixer consisting of D203-D206 (all 1SS16), where the incoming signal is mixed with the signal from the premix circuit. Schottky barrier diodes are used for the mixer to secure high dynamic range with low noise.

The mixer produces a 9 MHz IF signal at the output of T201. The IF signal is fed through a low-pass filter consisting of L201, C202, C201, and a diode switch D201 (1S1555), to the FILTER unit PB-1626.

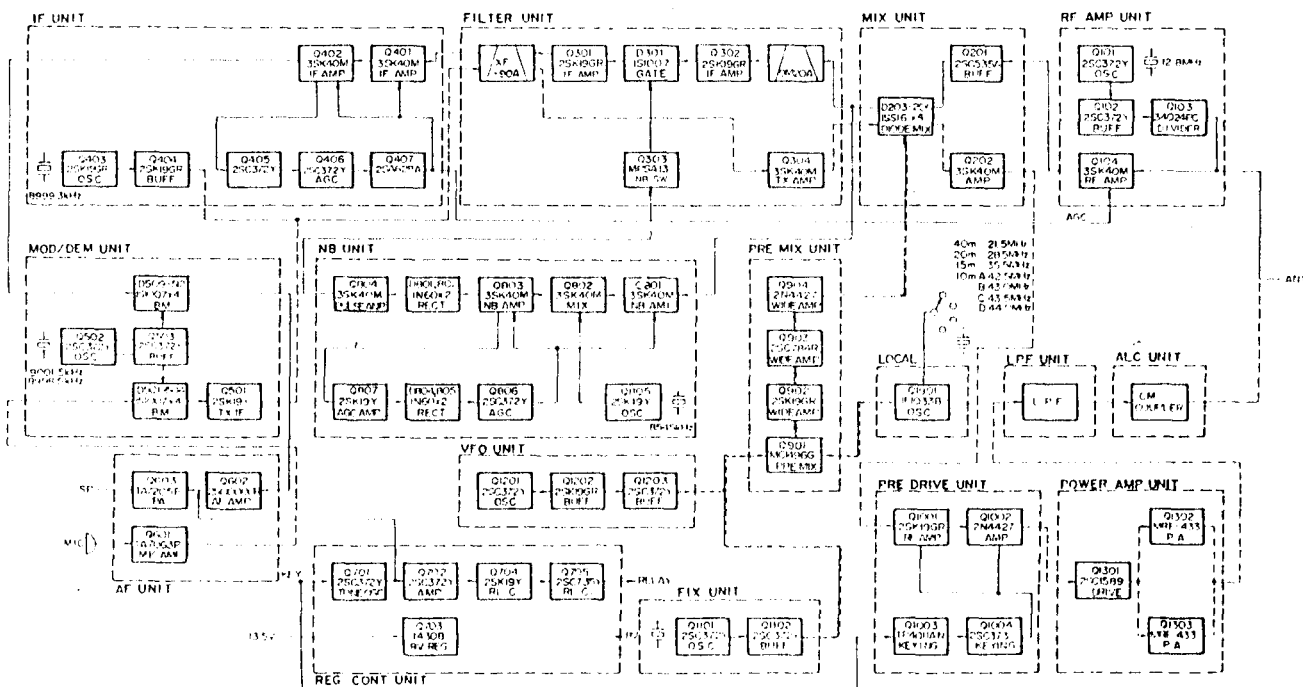

FT-7  
BLOCK DIAGRAM

## TRANSMITTER

Speech input from the microphone jack J2108 is fed through the MIC GAIN control VR2103 to pin 2 of the AF unit PB-1648. The speech signal is amplified by Q601 (TA7063P), then fed to the ring modulator D501-D504 (all 1S1007) in MOD/DEM unit PB-1624. The resulting 9 MHz DSB signal is amplified by Q501 (2SK19Y) and fed through a diode switch D505 (1S1555) to the FILTER unit.

The signal is amplified by a buffer, Q302 (2SK19GR), and fed to the crystal filter X302 where the unwanted sideband is rejected. The 9 MHz SSB signal generated by the filter is fed through diode switch D302 (1N60) to Q304 (3SK40M), and its output signal is fed to pin 4 of MIX unit PB-1631. The 9 MHz SSB signal is heterodyned to the desired RF frequency by injection of the local signal which is supplied from the PRE MIX unit PB1630A.

The RF output from the diode mixer is amplified by Q202 (3SK40M) and fed through diode switch D208 (1S1555) and bandpass transformers T1906-T1911 to PRE DRIVE unit PB-1632. Transformers T1906-T1911 are used on both transmit and receive to provide unsurpassed selectivity. The RF signal is amplified by Q1001 (2SK19GR) and Q1002(2N4427) and fed to the 10W AMP unit PB-1443. The output from the PRE DRIVE unit is amplified by the driver Q1301 (2SC1589) to drive the push-pull power amplifier consisting of Q1302 and Q1303 (both MRF 433), which produces a nominal power output of 10 watts.

A nonresonant, broadband power amplifier such as the one used in the FT-7, utilizing ferrites and the most advanced circuitry, eliminates the nuisance of having to tune up when changing bands.

The negative feedback circuitry, which consists of R1310, R1311, C1113, and C1114, stabilizes the final amplifier and delivers a clean signal to the output circuitry. Zener diode D1301 (YZ033) sets the bias for Q1301-Q1303 at exactly 3V.

Silicon diodes D1302 and D1303 (10D10) are mounted on Q1302 and Q1303, respectively, to compensate bias, as well as to protect them from thermal runaway.

The band switch S2102 selects the proper low-pass filter network for the band in use. The signal passes through T1501 in the ALC unit PB-1637 and the antenna relay RL 2102 to the antenna terminal J2101. T1501 detects the forward and reflected waves; the forward wave is rectified by D1502 (1S1007), and the reflected wave by D1504 (1S1007), to generate ALC voltage. The ALC threshold level of the forward wave is set by VR1501.

When there is an excessive amount of reflected power due to high SWR, the reflected wave is rectified by D1503 (1S1007) producing minus voltage to the ALC line. The ALC voltage reduces the gain of Q304 to prevent overloading or distortion.

The IF signal is passed through a monolithic filter X301 and is amplified by IF amplifiers Q301 and Q302 (both 2SK19GR). A noise blanker diode D301 (1S1007) is controlled by Q303 (MPSA13) to cut impulse noise.

The output from Q302 passes through an 8-pole crystal filter and a diode switch D303 (1N60), and is fed to the IF unit PB-1625. The signal is further amplified by Q401 and Q402 (both 3SK40M). The amplified signal is fed to the ring demodulator consisting of D509-D512 (all 1S1007). The carrier signal is also fed to the ring demodulator from the buffer amplifier Q503.

Audio output from the ring demodulator is fed to the AF unit PB1648 and is amplified by Q602 (2SC1009GR) and Q613 (TA7205P), to deliver 3 watts of audio signal to the speaker.

A part of the IF signal is fed to pin 2 of NB unit PB-1627. When the NB/MARK switch is placed in the NB position, the signal is amplified by Q801 (3SK40M) and fed to the gate of noise blanker mixer Q802 (3SK40M), where the 8545 kHz signal generated by Q805 (2SK19Y) is mixed with the incoming IF signal to produce a 455 kHz signal is then amplified by Q803 (3SK40M).

When a carrier or noise-free modulated signal is received, the 455 kHz signal with its corresponding strength is rectified by D801 and D802 (both 1N60) to charge C813. There is no discharge loop for C813; therefore, a signal which exceeds the charged voltage established by the reference voltage on C813 will not pass through D801 and D802. Accordingly, there will be no voltage drop across R819, and Q804 (3SK40M) will conduct as the gate voltage approaches zero, causing the drain voltage to drop.

The drain of Q804 is connected directly to the base of noise gate controller Q303 (MPSA13) in the FILTER unit. The voltage drop of the drain will turn off Q303, causing a forward bias to D301. As D301 conducts, the signal will pass through the circuit.

When impulse-type noise which exceeds the charged reference level voltage on C813 is received, D801 and D802 will permit negative-going pulses to turn off Q804. Thus, Q303 will conduct. As a result, D301 will be biased to block the signal passage.

The signal amplified by Q807 (2SK19GR) is rectified by D804 and D805 (both 1N60). The rectified DC voltage is amplified by DC amplifier Q806 (2SC372Y) and fed to the gate of Q801 and Q803 to control the gain of these stages.

The crystal-controlled marker generator Q101 (2SC372Y), located on the RF/MARK unit, generates a basic 12.8 MHz signal. The 12.8 MHz signal is fed through a buffer amplifier Q102 (2SC372Y) to a frequency divider Q103 (34024PC) to produce the 100 kHz marker signal. The 100 kHz marker signal is fed through pin 4 and pin 9 to the receiver front end.

For CW transmission, the crystal oscillator Q403 (2SK19GR) in the IF unit oscillates at 8999.3 kHz (the carrier frequency). This CW carrier is amplified by Q404 (2SK19GR) and fed through pin 5 to Q302 in the FILTER unit.

In the CW mode, the emitter voltage of Q1001 and Q1002 is controlled by the keying switch transistor Q1004 (2SC373). A flip-flop circuit utilizing Q1003 (MC14011B) is employed to secure a perfectly-shaped waveform for CW transmission free of clicks at any keying speed.

The tone oscillator Q701 (2SC373) operates when the MODE switch is in the CW position. It consists of a phase-shift oscillator operating at approximately 800 Hz. The tone output is activated by the keying circuit and is coupled to Q702 (2SC372Y) for semi-break-in CW operation. The relay delay hold time is adjusted by VR702. The output is also fed to Q603 (TA7205P) through level set potentiometer VR701 for CW sidetone monitoring.

### COMMON CIRCUITS

The carrier oscillator Q502 (2SC3724) is followed by a buffer amplifier Q503 (2SC372Y). It oscillates at either 8998.5 kHz (40-10 meters LSB, 80 meters USB) with X901 or 9001.5 kHz (40-10 meters USB, 80 meters LSB) with X902 depending on the mode of operation. The crystal selection is made by diode switches D507 and D508 (1S1555). The carrier is then fed through a relay RL501 to the ring modulator and demodulator.

The LSB crystal is used for CW reception on all bands. For CW transmission, the oscillator in the IF unit oscillates with X401.

A modified Colpitts type oscillator is used to generate a 5.0-5.5 MHz signal to produce a stable 500 kHz tuning range. The frequency is varied by VC1201, which is geared to a precision-built dial tuning mechanism.

The varactor diode D1201 (1S2236) is in series with C1207, and the combination is in parallel with VC1201. By closing the clarifier switch, the clarifier control shifts the receiver  $\pm 3$  kHz.

The VFO output signal is fed through the amplifier/buffer stage Q1202 (2SK19GR) and Q1203 (2SC372Y), the low-pass filter, and the diode switch D1202 (1S1555) to the PRE MIX unit PB1630.

In addition to normal VFO operation, a crystal-controlled channel may be used. Crystal oscillator Q1101 (2SC372Y) is followed by buffer amplifier Q1102 (2SC372Y), and its output is fed through the low-pass filter and diode switch D1901 (1S1555) to the PRE MIX unit. Trimmer capacitors TC1101-TC1105 are used for fine adjustment of each crystal frequency.

Crystal oscillator Q1901 (JF-1033) produces a heterodyne signal selected by the band switch. The signal is fed to the double balanced mixer Q901 (MC-1496G) in the PRE MIX unit PB-1630, where the signal is mixed with a signal from the VFO. The output from the mixer is fed through bandpass transformers T1902-T1905 to the broadband amplifier Q902 (2SK19GR), Q903 (2SC784R), and Q904 (2N4427). The premix output signal is then applied to the diode mixer in the MIX unit.

40m	X1902	21.5MHz	HC 18/U
20m	X1902	28.5MHz	HC 18/U
15m	X1903	35.5MHz	HC 18/U
10mA	※	42.5MHz	HC 25/U
10mB	X1901	43.0MHz	HC 25/U
10mC	※	43.5MHz	HC 25/U
10mD	※	44.0MHz	HC 25/U

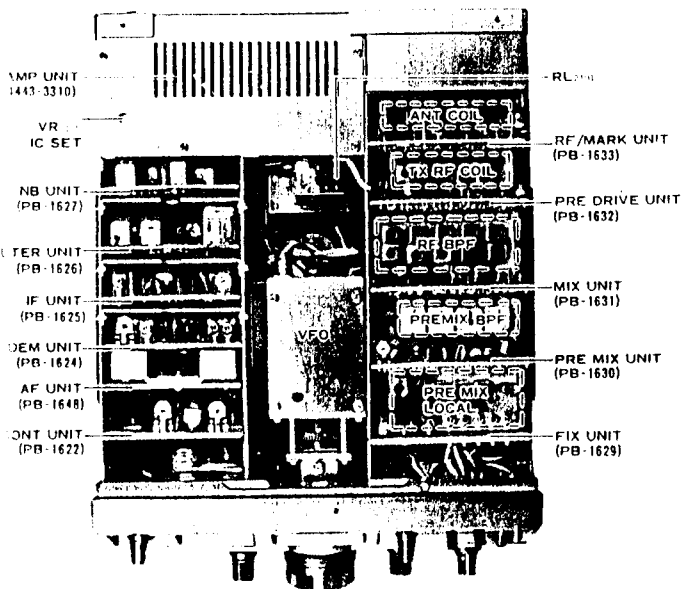

TOP VIEW

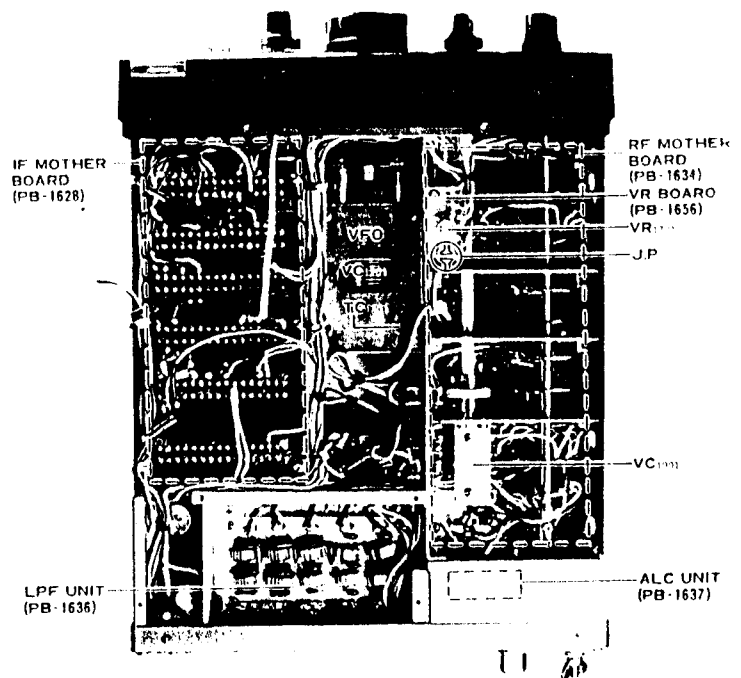

BOTTOM VIEW

## MAINTENANCE AND ALIGNMENT

### General

This transceiver has been carefully aligned and tested at the factory prior to shipment. The reliability of the solid state devices used in the FT-7 should provide years of trouble-free service if the equipment is not abused and the proper routine maintenance is carried out.

Do not attempt to align the transmitter without having a proper dummy load or antenna connected to the transceiver. We highly recommend off-the-air testing using a dummy load as a courtesy to other operators.

The following alignment procedure requires certain test equipment such as an RF signal generator, an audio oscillator, a sweep generator, an oscilloscope, and a VTVM. Without proper test equipment, do not attempt to adjust cores or potentiometers.

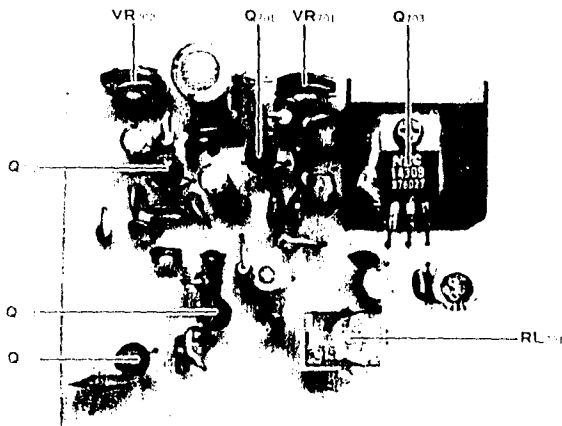

CONT UNIT(PB-1622)

### Control Unit (PB-1622)

- (1) CW relay delay adjustment (VR702):
  - (a) Connect a dummy load or matched antenna to the ANT connector. Connect a key to the KEY jack, and place the MODE switch in the CW position.
  - (b) When the key is closed and then opened again, it will be observed that there is a delay between the instant the transceiver returns to "receive". The length of the delay may be varied by adjustment of VR702, in order to provide the proper delay for the keying speed used and/or the preferences of the individual operator.
- (2) Sidetone level adjustment (VR701)
  - (a) The level of the CW sidetone may be adjusted by varying VR701 while the key is closed.

MOD/DEM UNIT (PB-1624)

(1) SSB carrier point (TC502, TC503):

- (a) Settings: BAND.....20  
DIAL..... 14.25 MHz  
MODE.....CW  
Peak the TUNE control to secure maximum output.
- (b) Place the MODE switch in the USB position. Connect the output of an audio oscillator to the microphone input. Set the frequency to 1 kHz and transmit on USB. Adjust the MIC GAIN control for 8 watts RF output to the dummy load.
- (c) Shift the audio frequency to 300 Hz without changing audio output level or MIC GAIN control.
- (d) Switch between USB and LSB while adjusting TC502 for USB and TC503 for LSB to obtain 2 watts output on each sideband. (Note: For the 80 meter band, TC502 will adjust LSB and TC503 will adjust USB, but the alignment here is taking place on 20 meters.
- (e) Return to the receive mode. Switch the MODE selector back and forth between USB and LSB. The tone quality of the background noise on the two sideband modes should sound alike.

(2) CARRIER BALANCE

- (a) Settings: BAND.....20  
DIAL. .... 14.25 MHz  
MODE.....USB  
No input to the mike jack.
- (b) Connect a dummy load to the antenna receptacle and the RF probe of a VTVM to the antenna receptacle, J2101. Adjust TC501 and VR501 alternately to minimize the VTVM reading.
- (c) If no VTVM is available, use a monitor receiver and adjust TC501 and VR501 for the minimum S meter reading.

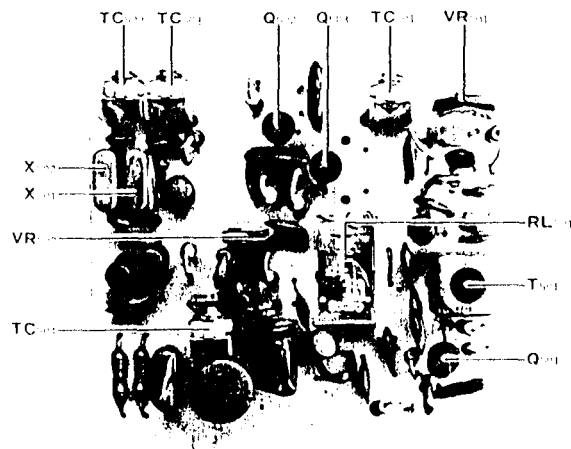

MOD/DEM UNIT(PB-1624)

## IF UNIT (PB-1625)

- (1) CW carrier level adjustment (TC401):
  - (a) Connect the RF probe of a VTVM to pin 2 of PB-1625. With the MODE switch in the CW position and the key closed, adjust TC401 for a reading of  $75 \text{ mV} \pm 10 \text{ mV}$ .
- (2) S-meter calibration (VR401):
  - (a) Place the band switch to 40 meters and the MODE switch to USB. Connect a signal generator to the antenna receptacle, and set the generator frequency to the receiver frequency.
  - (b) Adjust the signal generator output to 87 dB. Adjust VR401 for full scale S-meter deflection.

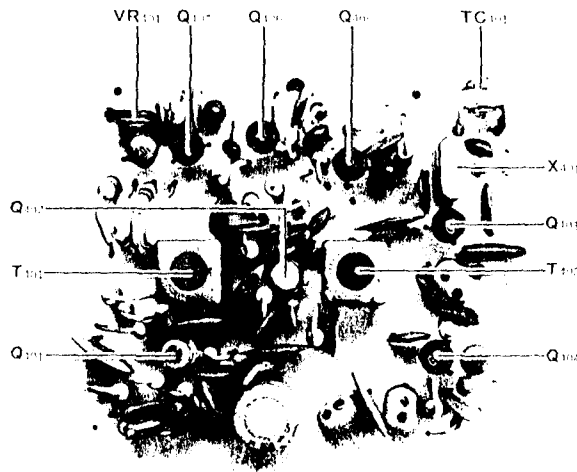

IF UNIT (PB-1625)

## LOCAL UNIT

- (1) Local oscillator level adjustment (T1901, TC1901-TC1904)
  - (a) Connect the RF probe of a VTVM to TP 1901. Place a crystal for the 10mD band (44 MHz) in the socket for the 10 meter band. Adjust the core of T1901 for a reading of 50 mV on the VTVM.
  - (b) Place the crystal for the 10mB band (43 MHz) in the 10 meter band crystal socket. Adjust TC1904 for a reading of 50 mV on the VTVM.
  - (c) Switch to the 15 meter band. Adjust TC1903 for a reading of 50 mV on the VTVM.
  - (d) Switch to the 20 meter band. Adjust TC1902 for a reading of 50 mV on the VTVM.
  - (e) Switch to the 40 meter band. Adjust TC1901 for a reading of 50 mV on the VTVM.

(2) Premix bandpass filter adjustment (T1902-T1905):

The adjustment of the bandpass filters is critical with respect to spurious response. A sweep generator and a scope are required for proper alignment.

- (a) Locate PB-1656, which can be found on the bottom side of the RF mother board (see photo on page ). Locate JP on PB-1656. For this alignment, remove the solder on the shorting device, breaking the connection.
- (b) Connect the output of a sweep generator to TP1901 and the RF probe of a scope to TP1902. Monitor the wave patterns on the scope by offsetting the balancing potentiometer VR901 on the PREMIX unit.
- (c) Set the VFO/FIX switch to FIX to disconnect the VFO from the circuit. Apply 30 dB sweep output to TP1901.
- (d) Adjust the bandpass filter transformer cores as follows, so that the passband characteristics become as flat as possible within the passband range specified, and maximum attenuation out of range.

<u>BAND</u>	<u>PASSBAND</u>	<u>CORE ADJUSTMENT</u>
40	16.0-16.5 MHz	T1902
20	23.0-23.5 MHz	T1903
15	30.0-30.5 MHz	T1904
10	37.0-37.5 MHz	T1905

PREMIX UNIT (PB-1630)

- (1) Premix balance (VR901):  
Connect the RF probe of a VTVM to TP1902. Place the VFO/FIX switch in the FIX position. Adjust VR901 for a minimum reading on the VTVM.

Transmit/receive frequency band-pass filter adjustment (T1906-T1915):

- (a) Connect the output of the sweep generator to the antenna receptacle, and the scope input to the emitter of Q201 on the MIX unit. Remove the IF unit, and cut off the AGC voltage. Connect a jumper between pin 10 and pin 11 of the RF unit, and connect a 100 Ohm resistor between pin 8 and pin 9 of the RF unit to reduce the input Q of the circuit.

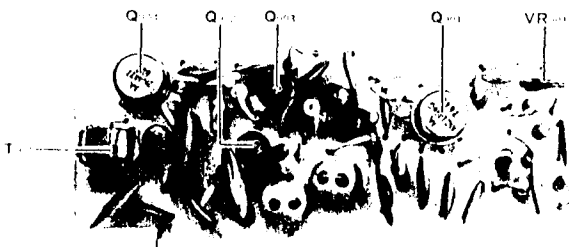

PRE MIX UNIT(PB-1630)

(b) Adjust the transformer cores as follows, to secure the most flat response possible over the passband indicated:

80m Band	3.5MHz~ 4.0MHz	(T1906, T1907)
40m Band	7.0MHz~ 7.5MHz	(T1908, T1909)
20m Band	14.0MHz~ 14.5MHz	(T1910, T1911)
15m Band	21.0MHz~ 21.5MHz	(T1912, T1913)
10m Band	28.0MHz~ 30.0MHz	(T1914, T1915)

(c) After making the necessary adjustments, return the circuitry to its original condition: remove the 100 Ohm resistor and jumper from the RF unit, restore the AGC voltage, and replace the IF unit.

(3) VFO unit (PB-1440A -3310)  
 Skilled technique is required as well as advanced knowledge to align the VFO unit. It is, therefore, recommended that all VFO work be referred to qualified personnel should a case develop where a repair is needed on the VFO unit.

TC1201: Band setting trimmer capacitor.

TC1202: A split-type trimmer capacitor for temperature compensation.

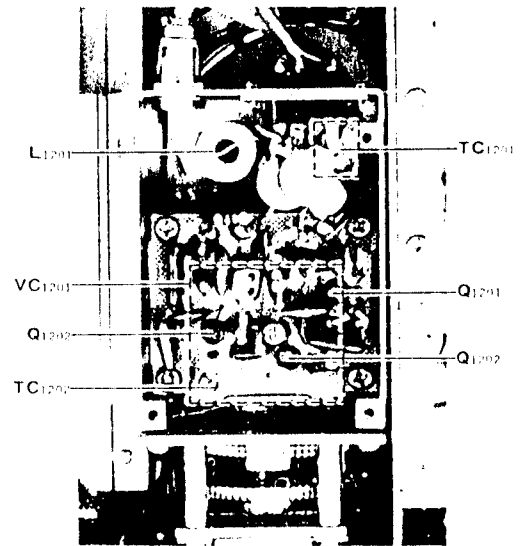
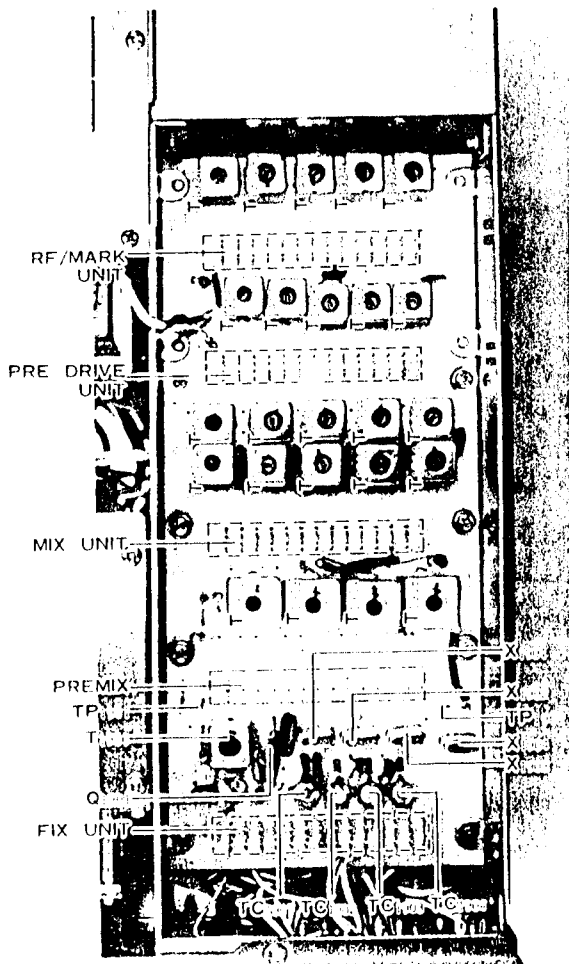

(4) It is possible to use one crystal controlled channel per band with the FT-7. The crystal should be inserted in the socket appropriate for the band to be used, and TC1101, 1102, 1103, 1104, and 1105 provide fine frequency tuning for the 80, 40, 20, 15, and 10 meter bands, respectively.

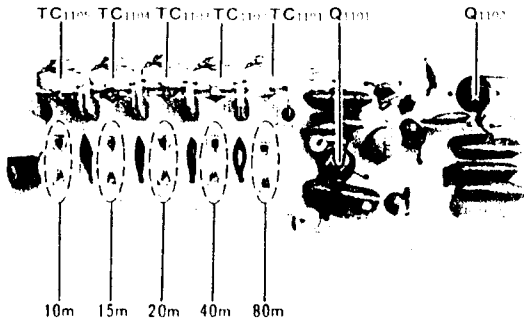

FIX UNIT(PB-1629)

(5) Clarifier zero setting (VR1701):

- (a) Tune the transceiver to the marker or a signal generator on any band.
- (b) Set the CLAR control to the 12 o'clock position. Turn on the CLAR switch, and tune the main dial for a zero beat to the marker or signal generator.
- (c) Now turn the CLAR switch to VFO, and if the tone of the marker or signal generator is changed (away from zero beat) secure zero beat by adjusting VR1701.
- (d) Replace the solder bridge on shorting device JP on PB-1656.

(6) RF tracking (T1916-T1925)

- (a) Connect a dummy load or matched antenna to the antenna receptacle on the rear panel. Set the transceiver controls as follows:  
 MODE.....CW  
 DIAL.....250  
 TUNE...Center scale ("5")
- (b) Set the band switch to 80. While transmitting, adjust T1916 for maximum power output into the dummy load.

(c) Repeat this procedure on each band, adjusting the transformers appropriate for the bands selected:

<u>BAND</u>	<u>CORE ADJUSTMENT</u>
40	T1917
20	T1918
15	T1919
10	T1920

(d) Remove the dummy load from the antenna receptacle and connect a signal generator to the antenna receptacle. While receiving, zero the signal generator output to the frequency to be adjusted (3750, 7250, etc.) and adjust the transformer cores below for maximum deflection of the S-meter:

<u>BAND</u>	<u>CORE ADJUSTMENT</u>
80	T1921
40	T1922
20	T1923
15	T1924
10	T1925

(e) Other coils:

<u>UNIT</u>	<u>COIL</u>	<u>PROCEDURE</u>
FILTER	T-301-	Peak to 9MHz on receive
	T-304	
	T305	Peak to 9MHz on transmit
IF	T401,	Peak to 9MHz on receive
	T402	
MOD/ DEM	T501	Peak to 9MHz on transmit
NB	T801	Peak to 9MHz on receive, NB ON
	T802,	Peak to 455 kHz on receive, NB ON
	T803	
	T804	Peak to 8545 kHz on receive, NB ON

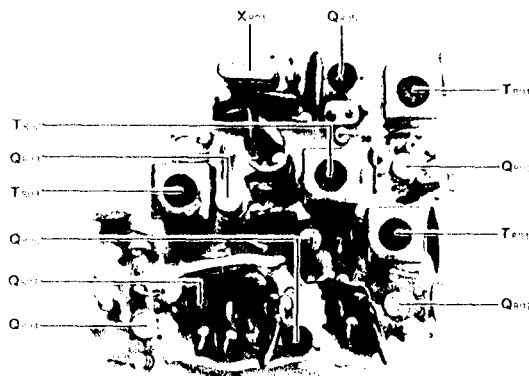

NB UNIT(PB-1627)

ALC UNIT (PB-1637)

- (a) Connect a dummy load to the antenna receptacle. Set VR1501 to the fully clockwise position. Peak the transmitter for maximum power output on 10 meters, CW mode. Adjust TC1501 for maximum power output to the dummy load.
- (b) Peak the transmitter for maximum output on 80 meters, CW mode. Slowly rotate VR1501 until the output power just starts to fall.
- (c) Care must be exercised when adjusting VR1501 using other than a 50 Ohm resistive dummy load; a high SWR condition on the transmission line will cause an improper setting of VR1501.

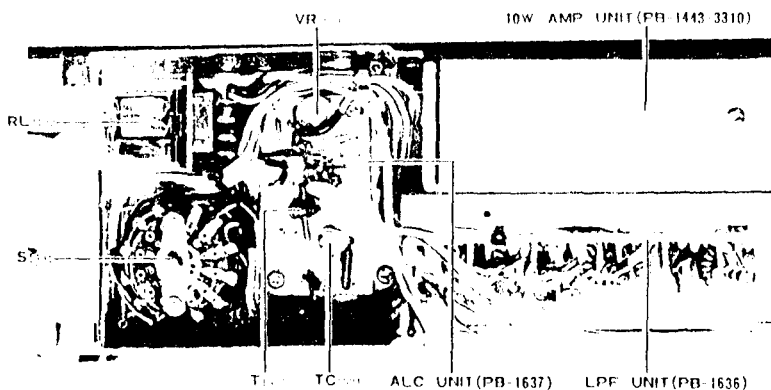

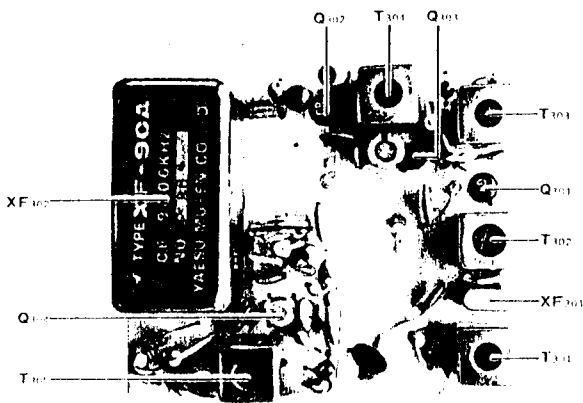

FILTER UNIT(PB-1626)

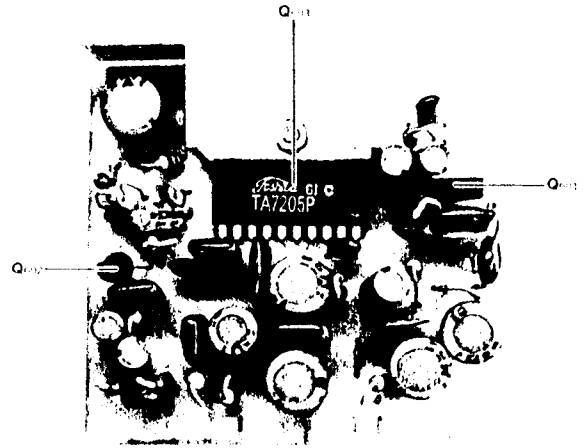

AF UNIT(PB-1648)

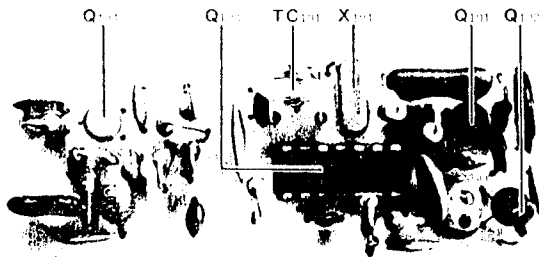

RF/MARK UNIT(PB-1633)

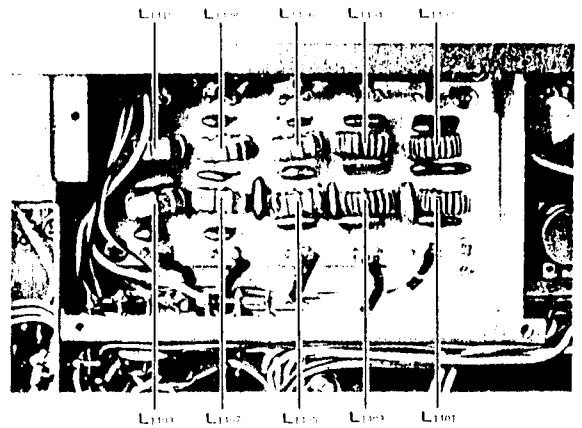

LPF UNIT(PB-1636)

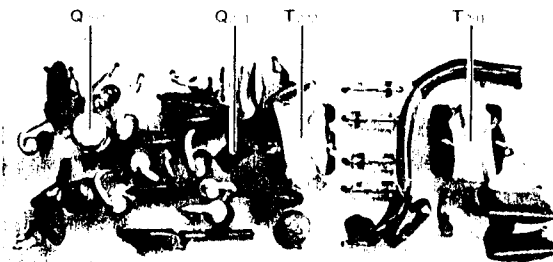

MIX UNIT(PB-1631)

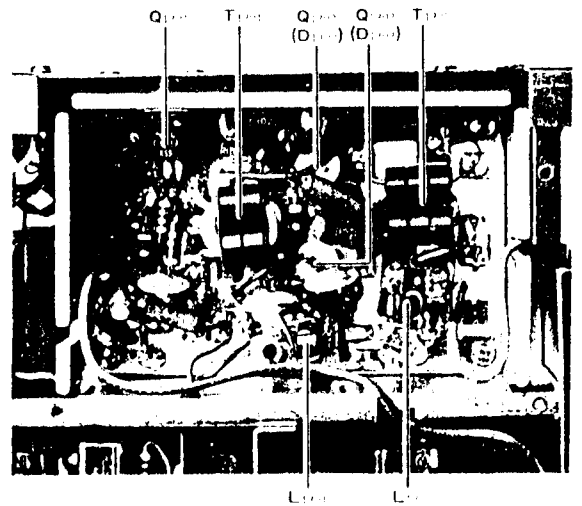

10W AMP UNIT(PB-1443-3310)

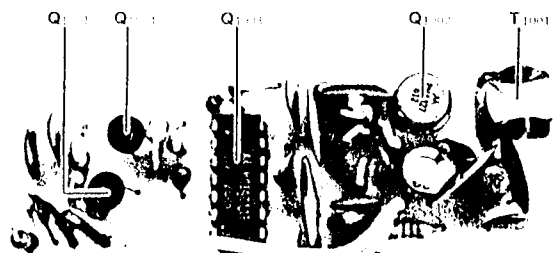

PRE DRIVE UNIT(PB-1632)

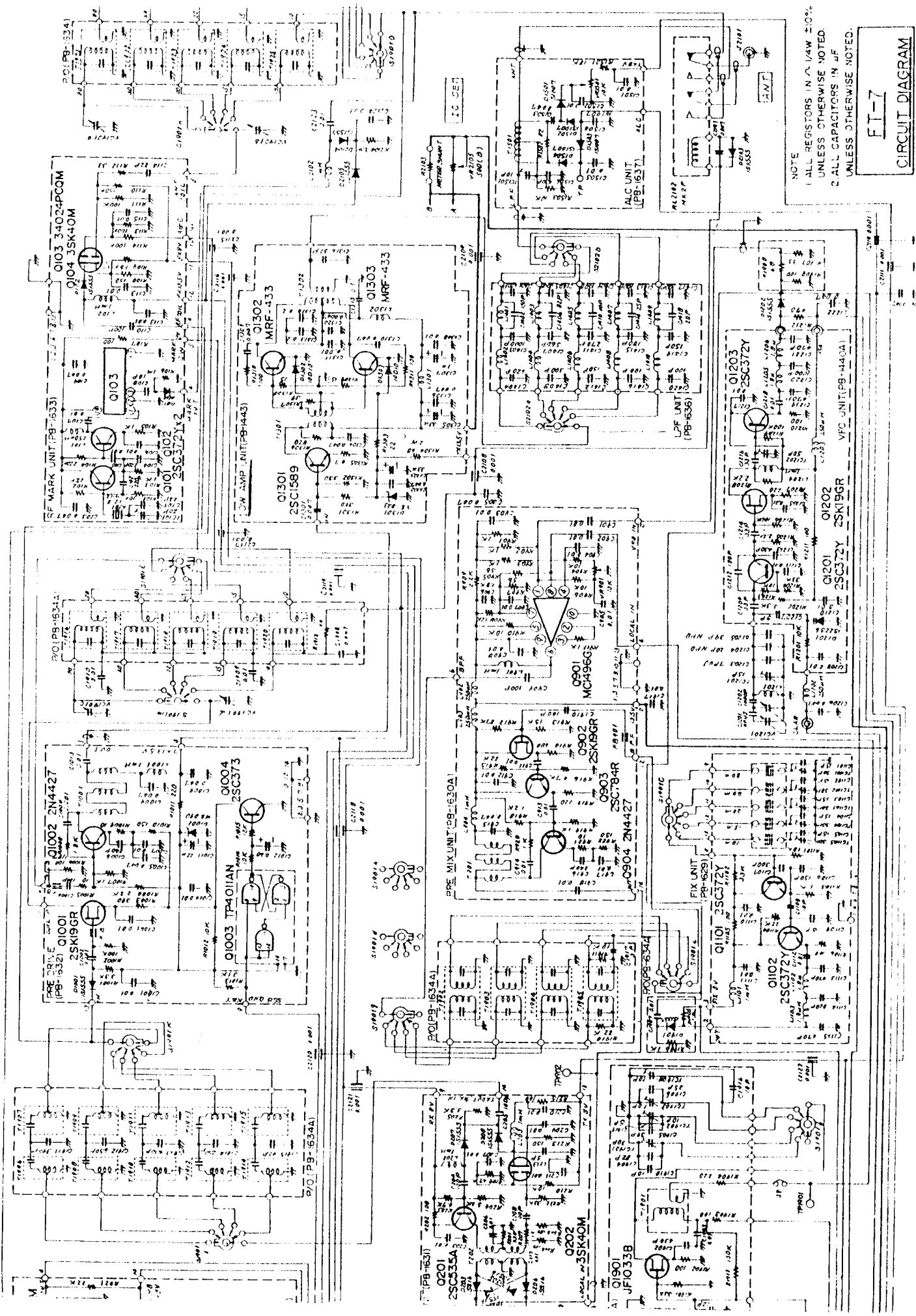

NOTE  
 1 ALL RESISTORS IN A 1/4W 20%  
 UNLESS OTHERWISE NOTED.  
 2 ALL CAPACITORS IN uF  
 UNLESS OTHERWISE NOTED.

FI-7  
 CIRCUIT DIAGRAM

RF MARK UNIT (PB-16331)  
 Q103 34024PCOM  
 Q104 35K40M  
 Q100 25K19GR  
 Q101 25K19GR  
 Q102 2N4427  
 Q103 25C372Y  
 Q104 25C372Y

LOW AMP UNIT (PB-14443)  
 Q1301 25C1589  
 Q1302 MRF-433  
 Q1303 MRF-433

PRE MIX UNIT (PB-1630A)  
 Q901 MCA96G  
 Q902 25K19GR  
 Q903 25C784R  
 Q904 2N4427

ALC UNIT (PB-1637)  
 Q1201 25K19GR  
 Q1202 25K19GR  
 Q1203 25C372Y  
 Q1204 25C372Y

PRE DRIVE (PB-1632)  
 Q1001 25K19GR  
 Q1002 2N4427  
 Q1003 25C372Y  
 Q1004 25C372Y

FIX UNIT (PB-1629)  
 Q1101 25C372Y  
 Q1102 25C372Y

VFC UNIT (PB-1440A)  
 Q1201 25K19GR  
 Q1202 25K19GR  
 Q1203 25C372Y  
 Q1204 25C372Y

Q201 25C535A  
 Q202 35K40M  
 Q1901 JF1033B

Q1001 25K19GR  
 Q1002 2N4427  
 Q1003 25C372Y  
 Q1004 25C372Y

